

Manual/Manual/Manual

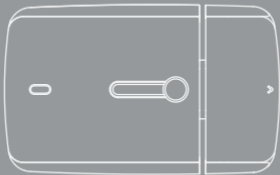

Español	-----	1
English	-----	25
Português	-----	49

RECOMENDACIONES DE USO

- ✓ Lea atentamente las instrucciones.
- ✓ Descárgue la APP wHome y regístrese como usuario.
- ✓ Compruebe el correcto funcionamiento del producto antes de instalar.
- ✓ No acerque el producto a llamas o calor directo.
- ✓ No sumerja ni salpique con ningún líquido el producto.
- ✓ Si ha pegado la Pieza Soporte a la puerta y en algún momento desea despegarla, se recomienda aplicar calor sobre la pieza, o bien, utilizar un spray adecuado para no dañar la puerta.

CONTENIDO DE LA CAJA

- ✓ wBolt
- ✓ Soporte base
- ✓ Recibidor
- ✓ Espaciadores
- ✓ Pieza de Instalación
- ✓ Tornillos 01 (x2)
- ✓ Tornillos 02 (x6)
- ✓ Tornillos 03 (x2)
- ✓ Pilas AA (x4)

ES

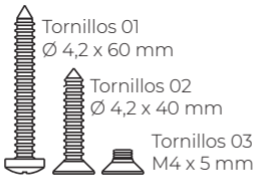

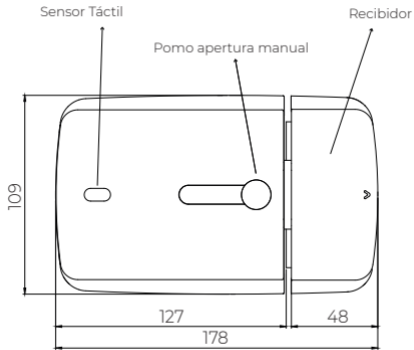

HERRAMIENTAS NECESARIAS



Taladro eléctrico



Broca para madera
de diámetro 2,5 mm



Marcador permanente



Destornillador con punta de
estrella (PH2)



Cinta métrica



Nivelador

PASOS A SEGUIR

* Si no quiere atornillar la wBolt a su puerta puede pegar la chapa base con cinta adhesiva de doble cara.

Para hacerlo debe seguir el paso 1.1 e ignorar los pasos 1.2, 2 y 3. De no ser así y desea atornillar la chapa base, puede ignorar el paso 1.1.

Es recomendable que antes de pegar el adhesivo limpie la zona de la puerta donde vaya a ponerlo.

1.1 Utilize la cinta adhesiva que incorpora la pieza Soporte Base. En este caso deberá quitar la lámina protectora de la cinta adhesiva y pegar el soporte base a la altura deseada de la puerta.

* Se recomienda que se deje mínimo 24 horas la chapa pegada a la puerta antes de seguir con la instalación, para que el adhesivo se seque bien.

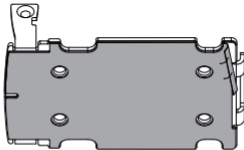

1.2 Elija el lugar donde quiere instalar el wBolt. Coloque el soporte base a la altura deseada y enráselo al borde de la puerta. Asegúrese que está recto usando el nivelador y marque los cuatro agujeros con el marcador.

* Compruebe que el lugar elegido no coincida con los puntos de seguridad de la puerta.

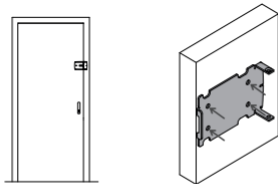

2 Retire el soporte base y taladre en las cuatro marcas.

* Si el grosor de su puerta mide menos de 40mm, debe comprar unos tornillos más cortos antes de taladrar.

2.1 Si su puerta está equipada con protección antipalanca deberá utilizar una pieza suplementaria. Pongáse en contacto con nosotros para obtenerla.

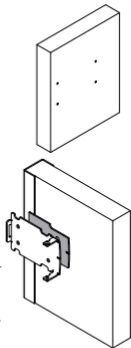

3 Atornille el soporte base con los tornillos 02.

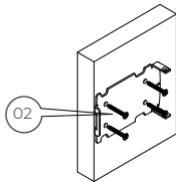

4 Con la cinta métrica mida la distancia que hay desde la ranura del soporte base hasta el suelo y apúntelo (cuando registre el producto en la APP lo va a necesitar).

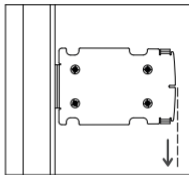

ES

5 Encaje el wBolt en el soporte base.

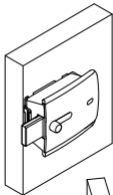
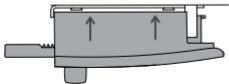

6 Una vez encajado, atornille las dos piezas en las patillas laterales con los tornillos 03.

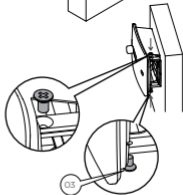

7 Saque la tapa del receptor empujando hacia fuera.

Atención:

Si desea más seguridad, antes de instalar el receptor en la puerta, puede cambiar el soporte base instalado en el receptor (1) por el otro soporte base (2), quitando los dos tornillos.

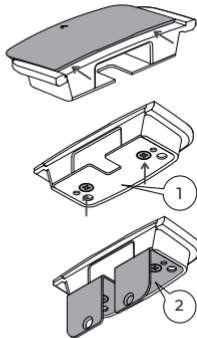

ES

8 Introduzca la Pieza de Instalación en el receptor.

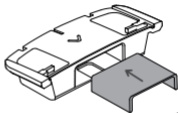

9 Encaje el receptor con el wBolt.

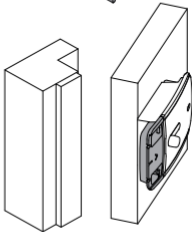

10 Con la puerta cerrada, observe la distancia que hay entre el marco de la puerta y el receptor. Esta diferencia de altura se debe suplementar con los espaciadores necesarios para que el receptor y el wBolt encajen correctamente.

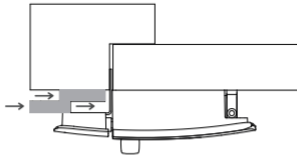

10.1 Si su puerta es acorazada, es posible que deba instalar más distanciadores. Contacte con nuestro servicio técnico.

11 Marque los dos agujeros en el marco de la puerta.

* Si ha decidido cambiar el soporte base del receptor, marque también los dos agujeros en el lateral del marco de la puerta.

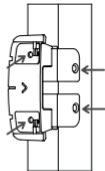
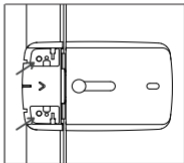

12 Abra la puerta. Retire el receptor y la Pieza de Instalación.

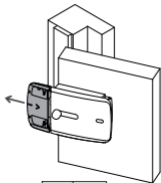

13 Taladre las dos (o cuatro) marcas. Vuelva a encajar el receptor y atornille con los tornillos 01 y 02, juntamente con los distanciadores y chapa de seguridad.

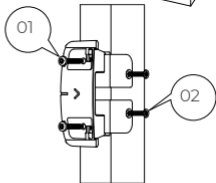

14 Ponga la tapa del receptor empujando hacia dentro.

15 Cierre la puerta. Introduzca las pilas y ponga la tapa en el wBolt.

* Fíjese en las marcas +/- de la tapa para poner las pilas correctamente.

16 Una vez instalado el producto, siga los pasos que le indica la APP.

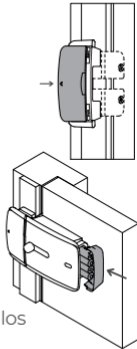

MANUAL INSTALACIÓN

1 Descargue la aplicación wHome de Watchman Door.

2 Para acceder a la aplicación, regístrese si es un nuevo usuario o inicie sesión si ya está registrado.

3 Si aún no tiene ningún producto instalado, seleccione el producto que desea instalar en la página principal.
Si ya tiene productos instalados, vaya a la página principal de la aplicación y haga clic en el logotipo '+' para asignar un nuevo producto de Watchman Door.



4 Escanee el código QR único del producto. Puede encontrarlo en la caja del producto o debajo de la tapa de las pilas.

* Asegúrese de que el producto esté alimentado antes de escanear el código QR.

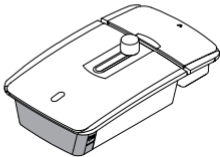

5 Una vez que se haya escaneado correctamente el código QR, la aplicación se conectará al producto a través de Bluetooth.

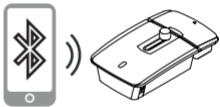

6 Una vez que haya accedido al producto, se abrirá automáticamente la configuración del mismo. Configure los parámetros deseados y guarde los cambios. *Es importante guardar la altura de instalación del wBolt en esta ventana.

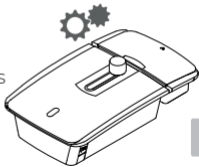

ES

7 Finalmente, guarde el producto con el nombre deseado y estará listo para disfrutar de todas sus funciones.

8 Una vez instalado el producto, puede acceder a la configuración en cualquier momento para modificar los parámetros mientras esté conectado a él.

APERTURA DE EMERGENCIA

Cuando el nivel de las baterías está por debajo del 5%, el wBolt solo hará la acción de abrir y no funcionará hasta que se cambien las baterías.

En caso de avería del producto, existe la posibilidad de efectuar una apertura manual de producto tanto desde el interior de la vivienda como desde el exterior. En ambos casos, contacte con Watchman Door para solucionar el problema con la mayor brevedad posible.

Si se encuentra en el interior de la vivienda solo tiene que mover el pomo hacia la dirección de apertura.

Si se encuentra en el exterior de la vivienda, siga los pasos siguientes:

1 Abra la aplicación wHome y acceda a la configuración del producto.

2 Como no es posible conectarse al producto, la aplicación mostrará la altura de instalación del wBolt.

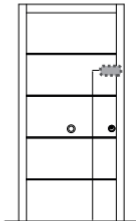

3 En la ubicación indicada (corresponde a la distancia guardada durante la instalación), realice un pequeño agujero en la tapa exterior de la puerta para acceder al mecanismo de cierre del producto.

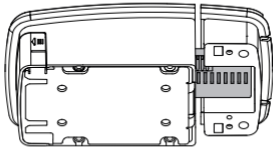

4 Por último, utilice un destornillador en los agujeros de cierre y ejerza presión para forzar la apertura del producto.

GARANTÍA Y SOPORTE

En caso de defectos, el comprador tiene que informar inmediatamente a Watchmandoor S.L. para reclamar el derecho a la solución de los mismos. Para poder reclamar los servicios con garantía es preciso presentar, dentro del

período de garantía, una prueba de compra válida con la fecha real de compra.

El comprador está obligado a poner la mercancía rechazada a disposición de

Watchmandoor S.L para comprobar si existe un supuesto cubierto por la garantía.

La garantía solo se aplica a los productos adquiridos directamente a Watchmandoor S.L o a un distribuidor/revendedor autorizado de Watchmandoor S.L.

La responsabilidad de Watchmandoor S.L se limita a la reparación o sustitución del producto. La decisión sobre si procede la reparación o la sustitución del producto quedará a la entera discreción de Watchmandoor S.L.

La garantía de los productos reparados o sustituidos se extenderá, en las condiciones aquí expuestas, por el resto del período de garantía original. En caso de sustitución del producto o de sus partes, estas pasarán a ser propiedad de Watchmandoor S.L.

Esta garantía puede reclamarse contactando con el soporte técnico de Watchmandoor S.L y será válida en todos los países.

Quedan excluidos de la garantía los defectos que surjan como resultado de: Las modificaciones o alteraciones del producto que sean atribuibles a una parte diferente a Watchmandoor S.L.

El mantenimiento inadecuado, la instalación incorrecta o la reparación defectuosa por una parte que no sea Watchmandoor S.L.

La apropiación indebida.

El uso inadecuado, los daños mecánicos, la sobretensión, la negligencia o los accidentes.

El desgaste habitual.

Ni Watchmandoor S.L ni ninguna de sus empresas asociadas serán responsables de las pérdidas o daños atípicos, accidentales, incluyendo consecuentes o punitivos. Esto incluye la posible pérdida de datos, beneficios, ingresos, producción, rendimientos de la inversión, pérdida de buena voluntad, costes de capital, costes de sustitución de equipos, instalaciones y servicios, y costes por tiempo de inactividad o fuera de servicio. La responsabilidad total de Watchmandoor S.L para todas las reclamaciones derivadas de esta garantía no excederá en ningún caso el precio pagado por el producto.

RECOMMENDATIONS FOR USE

- ✓ Read the instructions carefully.
- ✓ Download the wHome APP and register as a user.
- ✓ Check that the product works correctly before installing it.
- ✓ Keep the product away from flames or direct heat.
- ✓ Do not submerge the product or splash it with any liquid.
- ✓ If you have stuck the Bracket Part to the door and at any point you want to remove it, it is recommended that you apply heat to the part, or use a suitable spray, so as not to damage the door.

CONTENTS OF THE BOX

- ✓ wBolt
- ✓ Base bracket
- ✓ Receiver
- ✓ Spacers
- ✓ Installation part
- ✓ Receiver base bracket
- ✓ 01-type screws (x2)
- ✓ 02-type screws (x6)
- ✓ 03-type screws (x2)
- ✓ AA Batteries (x4)

EN

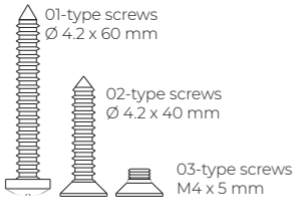

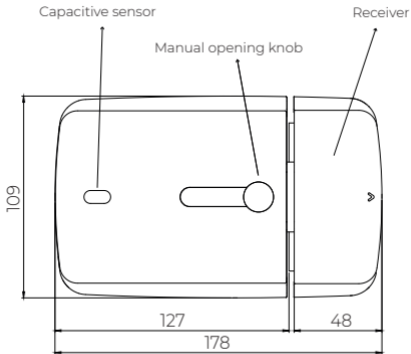

TOOLS REQUIRED



Electric drill



Wood drill bit - 2.5 mm diameter

EN



Permanent marker



Phillips head screwdriver (PH2)



Metric tape



Spirit level

STEPS TO BE FOLLOWED

* If you don't want to screw the wBolt to your door, you can use double-sided tape to stick the base plate. To do this, you need to follow step 1.1 and ignore steps 1.2, 2 and 3. If, instead, you want to screw on the base plate, you can ignore step 1.1.

It is recommended that you clean the area of the door where you are going to place it before sticking on the tape.

1.1 Use the adhesive tape included on the Base Bracket part. In this case, you will need to remove the protective film from the adhesive tape, and stick the base bracket at the desired door height

* It is recommended to leave the plate attached to the door for at least 24 hours before proceeding with the installation to allow the adhesive to dry properly.

EN

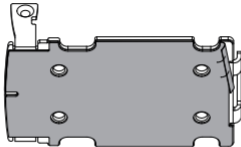

1.2 Choose the location where you want to install the wBolt. Place the base bracket at the desired height and make it level with the edge of the door. Ensure that it is level using the spirit level, and mark the four holes with the marker.

* Check that the chosen location does not line up with the door's security points.

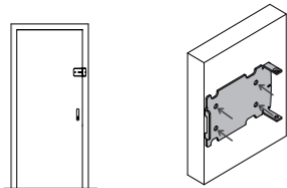

2 Remove the base bracket and drill the four holes at the markings.

* The door is less than 40 mm thick, you need to buy shorter screws before starting to drill.

EN

2.1 If your door is equipped with anti-pry protection, you will need to use an additional part. Get in touch with us and we'll send it to you.

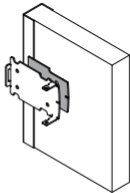
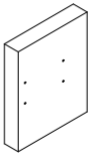

3 Screw in the base bracket with the 02-type screws.

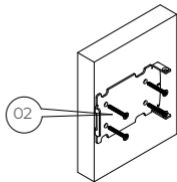

4 With the metric tape, measure the distance from the groove in the base bracket to the ground, and write it down (when you register the product in the APP you will need this).

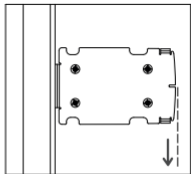

5 Fit the wBolt into the base bracket.

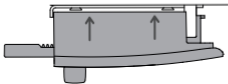

EN

6 Once fitted, screw the two parts together on the side tabs using 03-type screws.

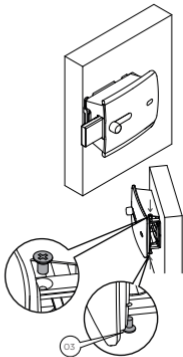

7 Take the cover off the receiver by pushing it outwards.

Please note:

If you want more security, before installing the receiver on the door, you can replace the base bracket that is installed on the receiver (1) with the other base bracket (2), removing the two screws.

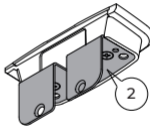
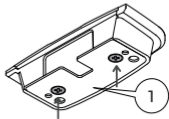
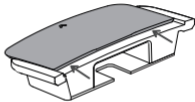

8 Place the installation part into the receiver.

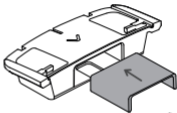

EN

9 Fit the receiver to the wBolt.

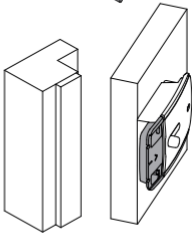

10 With the door closed, check how much distance there is between the door frame and the receiver. This height difference needs to be shimmed with the necessary spacers so that the receiver and the wBolt fit together correctly.

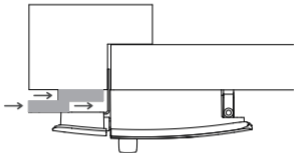

10.1 If your door is reinforced, you may need to install additional spacers. Please contact our technical service.

11 Mark the two holes on the door frame.

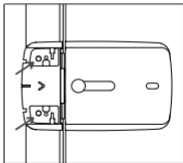

EN

* If you have decided to change the base bracket of the receiver, also mark the two holes on the side of the door frame.

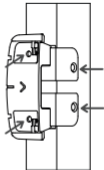

12 Open the door. Remove the receiver and the Installation Part.

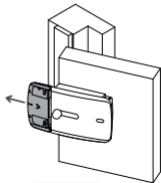

13 Drill the two holes (or four holes) at the markings. Fit the receiver again and screw it on with the 01-type and 02-type screws, together with the separators and the security plate.

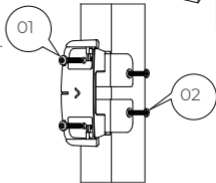

14 Put the cover back on the receiver by pushing it inwards.

15 Close the door. Place the batteries inside on the wBolt.

EN

* Pay attention to the +/- markings on the cover, so as to place the batteries the right way up.

16 Once the product is installed, follow the steps indicated in the APP.

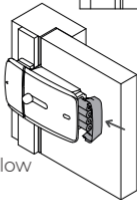
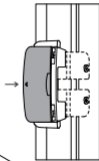

INSTALLATION MANUAL

1 Download the wHome application from Watchman Door.

2 To access the application, register if you are a new user or log in if you are already registered.



m
Z

3 If you don't have any products installed yet, select the product you'd like to install from the homepage. If you already have products installed, go to the application homepage and click on the '+' logo to assign a new Watchman Door product.

4 Scan the product's unique QR code. You can find it on the product's box or under the battery cover.

* Make sure that the product is connected to a power supply before scanning the QR code.

EN

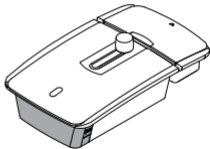

5 Once you have correctly scanned the QR code, the application will connect to the product through Bluetooth.

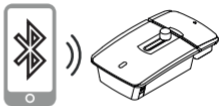

6 Once you have accessed the product, its settings will open automatically. Configure the parameters to your liking and save the changes.

* It is important to save the installation height of the wBolt in this window.

7 Finally, save the product with a name of your choosing and it will be ready for you to enjoy all its functions.

8 Once the product is installed, you can access its settings at any time to change the parameters while you are connected to it.



EMERGENCY OPENING

When the battery level is below 5%, the wBolt will only perform the opening action and will not work until the batteries are replaced.

In the event of a product malfunction, you can manually open the product from either inside or outside the residence. In both cases, please contact Watchman Door as soon as possible to resolve the issue.

EN

If you are inside the residence, you just have to move the knob in the opening direction.

If you are outside the residence, proceed as follows:

1 Open the wHome application and access the product settings.

2 Since it is not possible to connect to the product, the application will show the installation height of the wBolt.

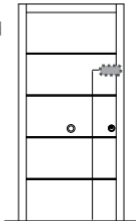

3 At the indicated location (the distance saved during installation) make a small hole on the outer cover of the door to access the product's closing mechanism.

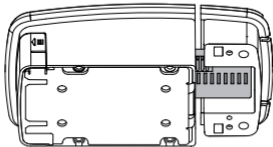

4 Finally, insert a screwdriver into the closing holes and exert pressure to force the product to open.

WARRANTY AND SUPPORT

In the event of defects, the purchaser must inform Watchmandoor S.L. immediately in order to exercise their right to have this resolved.

In order to claim warranty services, it is necessary to present, within the warranty period, valid proof of purchase with the correct purchase date.

The purchaser is obliged to return the rejected merchandise to Watchmandoor S.L. so that they can check whether or not the circumstance is covered by the warranty.

The warranty only applies to products purchased directly from Watchmandoor S.L., or a distributor/retailer that has been authorised by Watchmandoor S.L.

The responsibility of Watchmandoor S.L. is limited to the repair or replacement of the product. The decision on whether to proceed with the repair or replacement of the product shall be at the sole discretion of Watchmandoor S.L.

The warranty for repaired or replacement products shall be extended, under the conditions stated herein, for the remainder of the original warranty period.

In the event that the product or its parts are replaced, these shall become the property of Watchmandoor S.L.

This warranty can be exercised by contacting Watchmandoor S.L. Technical support, and it shall be valid in all countries.

Defects that occur as a result of the following shall be excluded from the warranty: Modifications or alterations to the product that are attributable to a party other than Watchmandoor S.L.

Unsuitable maintenance, incorrect installation, or defective repair by a party other than Watchmandoor S.L.

Misappropriation.

Improper use, mechanical damage, surges, negligence or accidents.

Normal wear and tear.

Neither Watchmandoor S.L., nor any of its associated companies, shall be responsible for exceptional or accidental losses or damage, including those that are consequential or punitive. This includes the possible loss of data, benefits, income, production, investment returns, loss of good will, capital costs, equipment, facility and service replacement costs, and costs for downtime, or time spent out of service. The total responsibility of Watchmandoor S.L. for all claims arising under this warranty shall not exceed, under any circumstances, the price paid for the product

RECOMENDAÇÕES DE UTILIZAÇÃO

- ✓ Leia as instruções com atenção.
- ✓ Transfira a APP wHome e registre-se como utilizador.
- ✓ Verifique o correto funcionamento do produto antes de instalar.
- ✓ Mantenha o produto longe de chamas ou calor direto.
- ✓ Não mergulhe nem salpique o produto com nenhum líquido.
- ✓ Se colou a Peça de Suporte à porta e, em algum momento, desejar descolar, recomenda-se que aplique calor sobre a peça ou utilize um spray adequado para não danificar a porta.

CONTEÚDO DA CAIXA

- ✓ wBolt
- ✓ Suporte da base
- ✓ Recetor
- ✓ Espaçadores
- ✓ Peça de instalação
- ✓ Suporte da base do recetor
- ✓ Parafusos 01 (x2)
- ✓ Parafusos 02 (x6)
- ✓ Parafusos 03 (x2) Pilhas
- ✓ AA (x4)

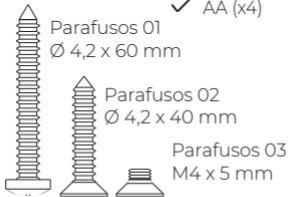

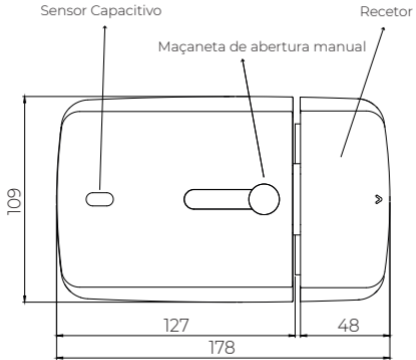

FERRAMENTAS NECESSÁRIAS



Berbequim elétrico



Broca para madeira de diâmetro
2,5 mm



Marcador permanente



Chave de fenda em cruz (PH2)



Fita métrica



Nível

PASSOS A SEGUIR

Se prefere não aparafusar a wBolt à sua porta, pode colar a chapa da base com fita adesiva de dupla face. Para o fazer deve seguir o passo 1.1 e ignorar os passos 1.2, 2 e 3. Caso contrário, se deseja aparafusar a chapa da base, pode ignorar o passo 1.1.

É recomendável que, antes de colar o adesivo, limpe a zona da porta onde o vai colocar.

1.1 Utilize a fita adesiva que vem na peça suporte da base. Neste caso, deverá retirar a camada protetora da fita adesiva e colar o suporte da base à altura desejada da porta.

* Recomenda-se deixar a placa fixada na porta por no mínimo 24 horas antes de prosseguir com a instalação, para que a cola seque corretamente.

PT

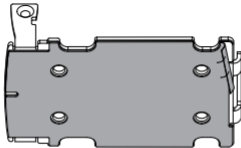

- 1.2** Escolha o local onde pretende instalar o wBolt.
Coloque o suporte da base à altura desejada e ajuste à borda da porta. Certifique-se de que está reto com o nível e marque os quatro orifícios com o marcador.
- * Se o local escolhido não coincide com os pontos de segurança da porta.

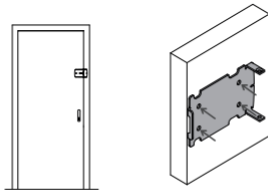

2 Retire o suporte da base e fure nas quatro marcas.

* A grossura da porta for inferior a 40 mm, deve comprar uns parafusos mais curtos antes de furar.

2.1 Se a porta está equipada com uma proteção de bloqueio de alavanca, terá de utilizar uma peça adicional. Entre em contacto connosco para obtê-la.

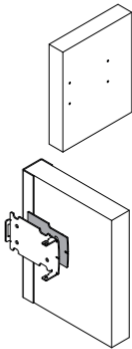

3 Aparafuse o suporte da base com os parafusos 02.

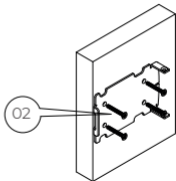

4 Com a fita métrica, meça a distância desde a ranhura do suporte da base até ao solo e aponte (quando registar o produto na APP, vai precisar).

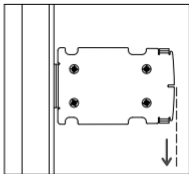

5 Fixe o wBolt no suporte da base.

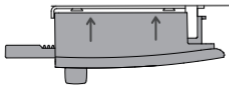

PT

6 Quando encaixado, aparafuse as duas peças nas patilhas laterais com os parafusos 03.

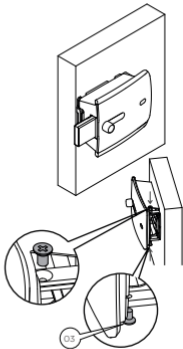

7 Retire a tampa do recetor empurrando para fora.

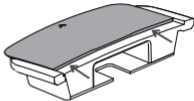

Cuidado:

se desejar mais segurança, antes de instalar o recetor na porta, pode trocar o suporte da base instalado no recetor (1) pelo outro suporte da base (2), retirando os dois parafusos.

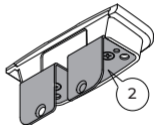
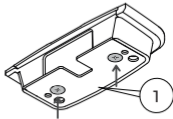

8 Introduza a Peça de instalação no recetor.

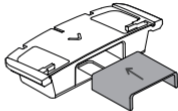

PT

9 Encaixe o wBolt no recetor.

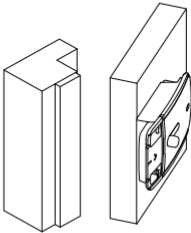

10 Com a porta fechada, observe a distância que há entre a moldura da porta e o recetor. Esta diferença de altura deve ser suplementada com os espaçadores necessários para que o recetor e o wBolt encaixem corretamente.

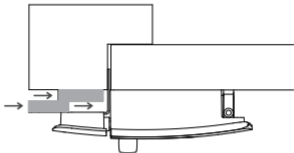

10.1 Se a porta for de segurança, é possível que tenha de instalar mais distanciadores. Contacte o nosso serviço técnico.

11 Marque os dois orifícios na moldura da porta.

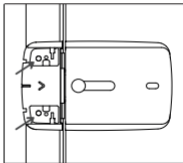

PT

* Decidiu mudar o suporte da base do recetor, marque também os dois orifícios na lateral da moldura da porta.

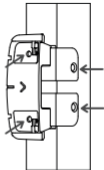

12 Abra a porta. Retire o recetor e a Peça de instalação.

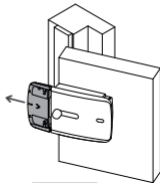

13 Fure as duas (ou quatro) marcas. Volte a encaixar o recetor e aparafuse com os parafusos 01 e 02, juntamente com os distanciadores e chapa de segurança.

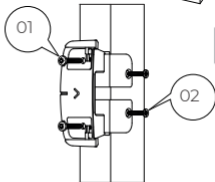

14 Coloque a tampa do recetor empurrando para dentro.

15 Feche a porta. Introduza as pilhas e coloque a tampa no wBolt.

PT

* As marcas +/- da tampa para colocar as pilhas corretamente.

16 Depois de instalado o produto, siga os passos indicados na APP.

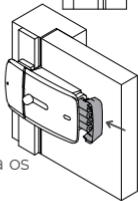
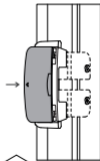

MANUAL DE INSTALAÇÃO

1 Transfira a aplicação wHome da Watchman Door.

2 Para aceder à aplicação, registe-se se for um novo utilizador ou inicie sessão se já estiver registado.

3 Se ainda não tiver nenhum produto instalado, selecione o produto que pretende instalar na página principal.

Se já tiver produtos instalados, aceda à página principal da aplicação e clique no logótipo “+” para atribuir um novo produto da Watchman Door.



4 Efetue a leitura do código QR exclusivo do produto. Pode encontrá-lo na caixa do produto ou sob a tampa do compartimento das pilhas.
*Certifique-se de que o produto está ligado antes de ler o código QR.

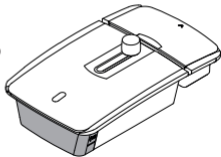

PT

5 Depois de ter lido o código QR com sucesso, a aplicação liga-se ao produto por Bluetooth.

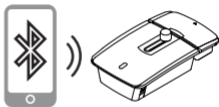

6 Depois de aceder ao produto, abre-se automaticamente a configuração do mesmo. Configure os parâmetros pretendidos e guarde as alterações.

* É importante guardar a altura de instalação da wBolt nesta janela.

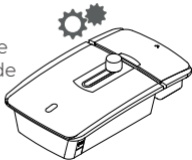

7 Finalmente, guarde o produto com o nome pretendido e está pronto para desfrutar de todas as suas funções.

8 Uma vez instalado o produto, pode aceder à configuração em qualquer altura para alterar os parâmetros enquanto estiver ligado ao mesmo.

ABERTURA DE EMERGÊNCIA

Quando a carga das pilhas for inferior a 5%, a wBolt apenas efetuará a ação de abertura e não funcionará enquanto não substituir as pilhas.

Em caso de avaria do produto, existe a possibilidade de abertura manual do produto, tanto a partir do interior da casa como do exterior. Em ambos os casos, contacte a Watchman Door para resolver o problema o mais rapidamente possível.

PT

Se estiver no interior da casa, só tem de deslocar o manípulo no sentido da abertura.

Se estiver fora de casa, siga os passos abaixo:

1 Abra a aplicação wHome e aceda à configuração do produto.

2 Como não é possível ligar-se ao produto, a aplicação apresenta a altura de instalação da wBolt.

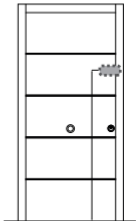

3 No local indicado (corresponde à distância guardada durante a instalação), faça um pequeno furo na tampa exterior da porta para aceder ao mecanismo de fecho do produto.

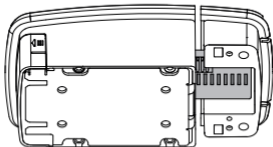

4 Por último, utilize uma chave de fendas nos orifícios de fecho e exerça pressão para forçar a abertura do produto.

GARANTIA E SUPORTE

Caso existam defeitos, o comprador deve informar, de forma imediata, a Watchmandoor S.L. para reclamar o direito à solução dos mesmos.

Para poder reclamar os serviços com garantia, é obrigatório entregar, dentro do período de garantia, um comprovativo de compra válido com a data real da compra.

O comprador é obrigado a colocar os produtos rejeitados à disposição da Watchmandoor S.L. para esta comprovar se existe verdadeiramente um caso de cobertura pela garantia.

A garantia aplica-se apenas aos produtos adquiridos diretamente à Watchmandoor S.L. ou a um distribuidor/revendedor autorizado pela Watchmandoor S.L.

A responsabilidade da Watchmandoor S.L. limita-se à reparação ou substituição do produto. A decisão sobre se reparar ou substituir o produto fica inteiramente à discrição da Watchmandoor S.L.

A garantia dos produtos reparados ou substituídos será estendida, nas condições aqui mencionadas, pelo restante período de garantia original. Em caso de substituição do produto ou partes do mesmo, estas passam a ser propriedade da Watchmandoor S.L.

Esta garantia pode ser reclamada contactando o apoio técnico da Watchmandoor S.L. e será válida em todos os países.

Os defeitos que resultem dos seguintes fatores são excluídos da garantia:

Modificações ou alterações do produto que sejam atribuídas a terceiros alheios à Watchmandoor S.L.;
Manutenção inadequada, instalação incorreta ou reparação defeituosa por um terceiro alheio à Watchmandoor S.L.;
Apropriação indevida;
Uso inadequado, danos mecânicos, sobretensão, negligência ou acidentes;
Desgaste normal.

Tanto a Watchmandoor S.L. como as empresas associadas à mesma permanecem excluídas da responsabilidade por perdas ou danos anómalos, acidentais, incluindo os consequentes ou punitivos. O supracitado exclui possíveis perdas de dados, benefícios, ingressos, produção, rendimentos do investimento, perda de boa-fé, custos de capital, custos de substituição de equipamentos, instalações e serviços e custos por tempo de inatividade ou fora de serviço. A responsabilidade total da Watchmandoor S.L. em todas as reclamações derivadas desta garantia não excederá em nenhum caso o preço pago pelo produto.

APP



Bluetooth

MADE IN
SPAIN



**WATCHMAN
DOOR**

WATCHMANDOOR S.L
ESB66853722 - Carretera de Santiga, 86
08291 Ripollet - Barcelona - España

info@watchmandoor.com
www.watchmandoor.com